

Product Information



Control 4000 Photometric Analyzers

Control 8000 Universal Analyzers



english

deutsch

español

portuguese

русский язык

中文

日本語

français

italiano

For over 25 years, optek has focused on measuring process liquids through their interaction with light in facilities all over the world. Although global, optek remains a family owned company with a team of more than 100 qualified, customer-driven professionals.

Our confidence is born from experience. With the expertise of more than 30,000 installations worldwide, our value to the customer resides in providing a superior product that pays back. High quality materials withstand the toughest process conditions including aggressive media, high temperature, and

high pressure applications. Cleanability is ensured using high quality wetted materials, superior design, as well as sapphire optical windows.

As a global partner to various industries, optek offers the most advanced technologies including superior signal amplification, inline calibration support, PROFIBUS® PA, and multilingual user interfaces for easy onsite operations.

Our support ensures long term satisfaction with programs such as “Speed-Parts” and “SwapRepair” to provide our customers sustainable operations and

minimized downtime at the lowest cost of ownership.

Conformity to international (ISO 9001), industry-specific (FM/ATEX approval) or company standards is easily achieved with optek. Wherever process composition is controlled, the name optek has become synonymous with world-class products and support.

**Optimize your process
with optek inline control.**



Content

C4000 / C8000 – converters	03
C4000 – photometric converter (configurations)	04
C8000 – universal converter (configurations)	06
C4000 / C8000 – accessories	08
C4000 / C8000 – technical data	09
Optical sensors – overview	10
Optical sensors – principles	11
Turbidity sensors AF16-N / TF16-N	12
Color sensors AF16-F / AF26	14
UV sensors AF45 / AF46	16
Probe sensors AS16 / AS56	18
Conductivity sensor ACF60	20
pH electrode adapter PF12	21
Sensor body (armature)	22
System – calibration	23
optek – worldwide contact	24

See our TOP 5 brochures for applications in your industry.



Control 4000 and Control 8000 are powerful, microprocessor-based converters.

The advanced modular design enables precision process monitoring and control with multiple sensors. The menu-based software is easy to use and configure, and available in German, English, French, Dutch, Spanish, Russian and Portuguese. The software includes adjustable signal damping, 16 linearization tables, advanced calculation capabilities. Multiple outputs transmit the measurements in real-time for precise process control. An integrated data logger captures vital process information for quality assurance and plant control records. This data is easily transferred to a PC via an RS232 port.

C4000 - Photometric Converter

The Control 4000 photometric converter is designed for optek ultraviolet (UV), visible (VIS), near-infrared (NIR) absorption based and scattered light based sensors.

The graphic display can show absorbance, transmittance, and concentration in real-time and in any unit of measure such as CU, OD, %-Tr., ppm (DE), EBC, FTU, g/l and many others.

These measurements may also be displayed as text, bar graphs or trend values. A factory zero is implemented as an additional feature for scattered light sensors. A secondary user zero for additional offset is included, as well as a slope and shift adjustment. This manual adjustment can be used to compensate for long term process related disturbances.

C8000 - Universal Converter

The Control 8000 universal converter operates optek photometric sensors along with 2 pH-probes and 2 conductivity sensors (optek patented ACF series) simultaneously.

All measurements (2 x optical, 2 x pH, 2 x conductivity and 2 x temperature) are transmitted with the standard 8 mA-outputs and may also be displayed as text and/or bar graphs.

The combination of C8000 and ACF60 conductivity sensors allows a wide dynamic range from 0 - 10 μ S/cm up to 0 - 850 mS/cm with the same sensor.

Sensors	C4000	C8000
Optical sensors (optek)	1 - 4	1
pH-Probes	—	2
Conductivity sensors (optek)	—	2
Communications	C4000	C8000
mA-outputs (0/4 - 20 mA)	2 / 4	8
mA-inputs (4 - 20 mA)	0 / 2	—
Relay-outputs	3	—
Failsafe-relay (active)	✓	✓
Remote-IN: Zero	✓	✓
Remote-IN: Range	✓	✓
Remote-IN: Hold	✓	—
Profibus® PA	✓	—
Explosion-proof	C4000	C8000
Ex-proof ATEX	✓	—
Ex-proof FM	✓	—

04 | C4000 - Photometric Converter



Sensor		4101	4201	4202	—	—
1	2	4121	4221	4222	4322	4422
		4151	4251	4252	4352	4452
AF16 (AS16)	—	✓	✓	✓	✓	✓
AF16 (AS16)	AF16 (AS16)	—	—	✓	✓	✓
AF16 (AS16)	AF26 or AF45 or TF16	—	—	—	✓	✓
AF26	—	—	✓	✓	✓	✓
AF26	AF26 or AF45 or TF16	—	—	—	—	✓
AF45	—	—	✓	✓	✓	✓
AF45	AF45 or TF16	—	—	—	—	✓
AF46	—	—	—	—	—	✓
TF16	—	—	✓	✓	✓	✓
TF16	TF16	—	—	—	—	✓

*C4422 can handle up to 4 sensors AS56

The Control 4000 is available in various configurations to meet the exact needs of your process.

- Multiple photometric sensors
- Multiple parameter sets
- Multiple linearization tables
- Data logger
- Factory zero for scattered light sensors
- Remote control
- Ex proof versions FM and ATEX

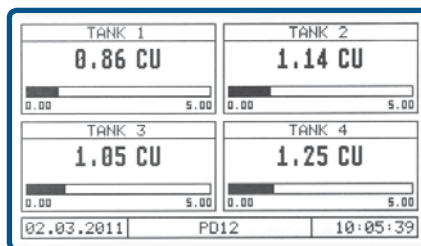
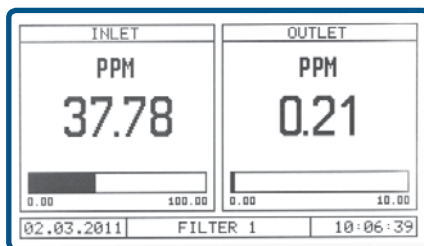

Display Modes

- 1 - 4 simultaneously displayed values (configurable)
- Numeric with bar graph and alarm setting
- Trendline

Software Tools

- 8 parameter sets (incl. range, alarm, display, etc.)
- 16 linearization tables (max. 11 points)
- 8 offset and slope sets
- Auto zero (local or remotely activated)
- Factory zero (scattered light sensors only)
- Password protection (3 levels and none)
- Memory (non-volatile) retains all configurations and logged data

Remote Control

- Parameter set
- Zero
- Hold

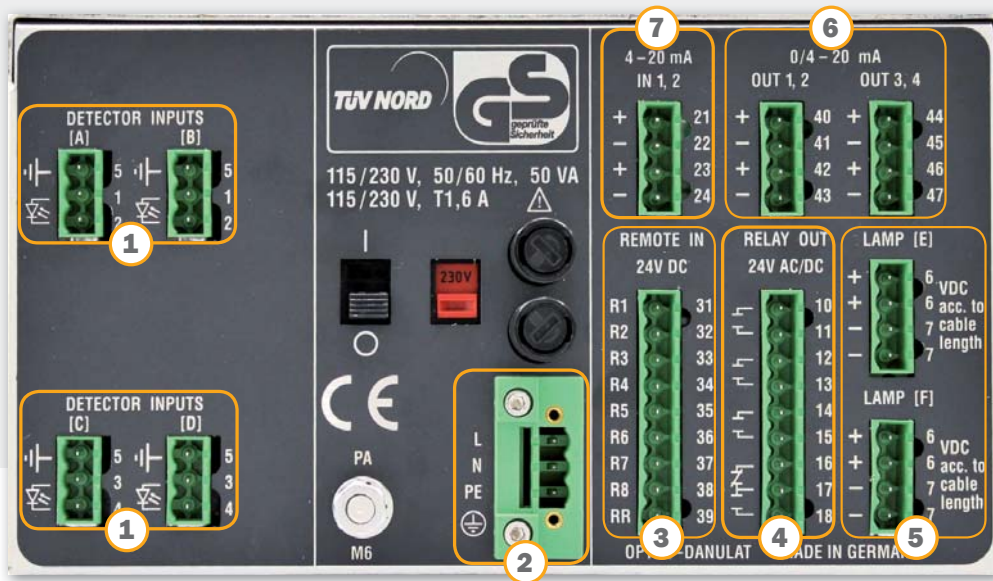

C4000 Configuration		4101	4201	4202	4121	4151	4221	4251	4222	4252	4322	4352	4422	4452
Detector inputs (optek)	①	1	2	2	1	1	2	2	2	2	3	3	4	4
Power supply 115/230 or 24 V	②	✓	✓	✓	✓	✓	✓	✓	✓	✓	✓	✓	✓	✓
Remote-IN: (Zero, Range, Hold)	③	—	—	—	✓	—	✓	—	✓	—	✓	—	✓	—
Relay-outputs	④	3	3	3	3	3	3	3	3	3	3	3	3	3
Failsafe-relay (active)	④	✓	✓	✓	✓	✓	✓	✓	✓	✓	✓	✓	✓	✓
Lamp outputs (optek)	⑤	1	1	2	1	1	1	1	2	2	2	2	2	2
mA-outputs (0/4 - 20 mA)	⑥	2	2	4	2	2	2	2	4	4	4	4	4	4
mA-inputs (4 - 20 mA)	⑦	—	—	—	2	—	2	—	2	—	2	—	2	—
Profibus® PA	⑧	—	—	—	—	✓	—	✓	—	✓	—	✓	—	✓
pH-probe		— (with C8000 only)												
Conductivity (optek ACF)		— (with C8000 only)												
Ex-proof (optional)		✓	✓	✓	✓	✓	✓	✓	✓	✓	✓	✓	✓	✓

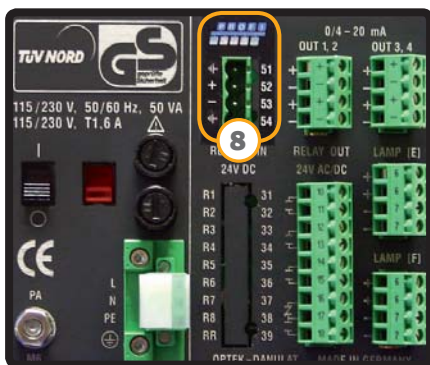

C4000 PROFIBUS® PA

The PROFIBUS® PA version allows you:

- Product change P01 - P08
- System zero point
- Hold
- Displaying all four measuring results of each product with: name, unit, limit values and corresponding status information
- Switching status of the four relay outputs

- Reading out detailed information on the state of the converter:
- Lamp monitor
- Detector monitor
- Sensor information
- List of available product names
- Number of error messages

06 | C8000 - Universal Converter



C8000 Sensor Combination	C8480
1 optical sensor	
AF16 VIS-NIR Absorption	✓
AS16 VIS-NIR Absorption	✓
AF26 Dual channel color	✓
AF45 UV-Absorption	✓
AF46 Dual channel UV	✓
TF16 11° scattered light	✓
4 electrochemical sensors	
pH-probe	2
Conductivity optek ACF (6-pol)	2

Software Tools

- 8 parameter sets (incl. range, display etc.)
- 16 linearization tables (max. 11 points)
- 8 offset and slope sets
- Auto zero (local or remotely activated)
- Factory zero (scattered light sensors only)
- Password protection (3 levels and none)
- Memory (non-volatile) retains all configurations and logged data

The Control 8000 is available in various configurations to meet the exact needs of your process.

- 1 photometric sensor
- 2 conductivity sensors
- 2 pH sensors
- Multiple parameter sets
- Multiple linearization tables
- Data logger
- Factory zero for scattered light sensors
- Remote control

Remote Control

- Parameter set
- Zero

Display Modes

- 2 - 8 simultaneously displayed values (configurable)
- Numeric with bar graph

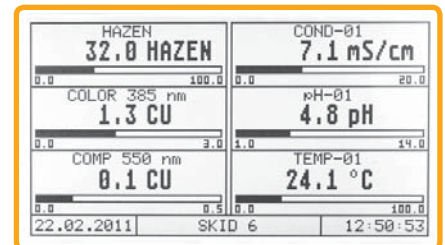
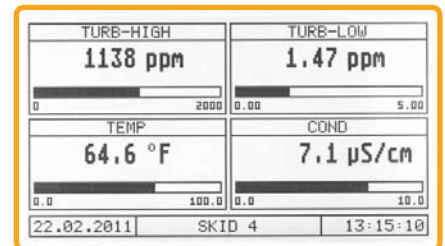
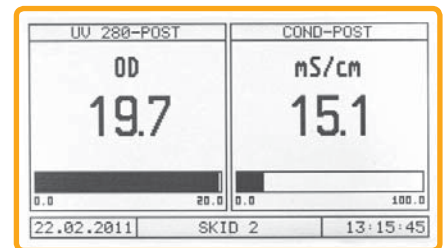

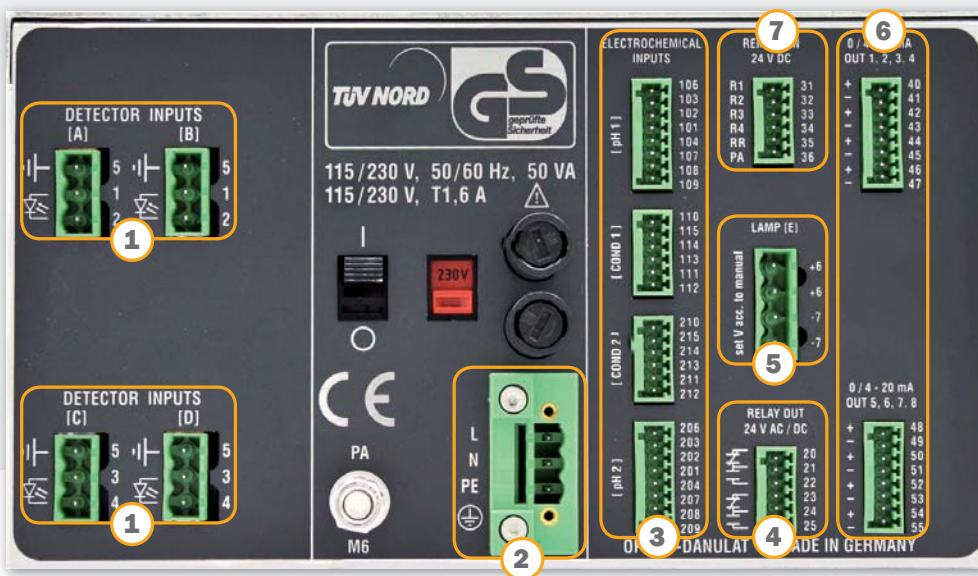

8 Measurements

5 Sensors

3 Armatures

1 Converter

The C8000 provides optical density or forward scatter turbidity measurements in the ultraviolet (UV), visible (VIS), and near infrared (NIR) ranges. In addition to optical sensors, the C8000 monitors up to two pH sensors and two conductivity sensors with integrated temperature measurements. One converter assures easy operation with an intuitive user interface in a compact package.

C8000 - Configuration		C8480
Detector inputs (optek)	①	4
Power supply 115/230 or 24 V	②	✓
Remote-IN: (Zero, Range)	⑦	✓
Relay-outputs		—
Failsafe-relay (active)	④	✓
Lamp output (optek)	⑤	✓
mA-outputs (0/4 - 20 mA)	⑥	8
mA-inputs (4 -20 mA)		— (with C4000 only)
Profibus® PA		— (with C4000 only)
pH-probe		2
Conductivity (optek ACF)	③	2
Ex-proof (optional)		— (with C4000 only)

Application (example):

Pre- and post-column chromatography monitoring

During purification, accurate, reliable and repeatable measurement is necessary to ensure accurate pooling to maximize yields and protein/DNA fraction purity.

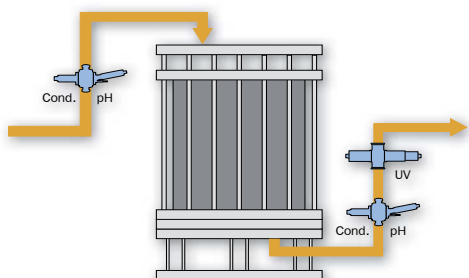

1 Converter	3 Armatures	5 Sensors	8 Measurements
C8480	Line size: 0.50 in. Clamp Tc L14 AM7 PN: 0120-3507-33 OPL: 5 mm Volume: < 22 ml Height: 96 mm (3.78 in.)	AF46 Dual Channel UV Absorption	UV Absorption at 280 nm UV Absorption at 300 nm
	Line size: 0.50 in. Clamp Tc L14 AM7 PN: 0120-3508-33 Volume: < 44 ml Height: 96 mm (3.78 in.)	ACF60 (patented 6 electrode probe based on 4 pole technique) PF12 (various pH electrodes)	Conductivity 0 - 10 µS/cm to 0 - 850 mS/cm Temperature -10 °C - 135 °C (14 - 275 °F) pH 0 - 14 pH
	Line size: 0.50 in. Clamp Tc L14 AM7 PN: 0120-3508-33 Volume: < 44 ml Height: 96 mm (3.78 in.)	ACF60 (patented 6 electrode probe based on 4 pole technique) PF12 (various pH electrodes)	Conductivity 0 - 10 µS/cm to 0 - 850 mS/cm Temperature -10 °C - 135 °C (14 - 275 °F) pH 0 - 14 pH
	Line size: 0.50 in. Clamp Tc L14 AM7 PN: 0120-3508-33 Volume: < 44 ml Height: 96 mm (3.78 in.)	PF12 (various pH electrodes)	pH 0 - 14 pH

08 | C4000/C8000 - Accessories

The PC-Transfer software allows communication between converter and PC via a RS-232 port. Documentation and set-up including identical set-up of multiple converters are made simple.

Converter to PC:

- Parameter set
- Trend data online
- Data logger

PC to converter:

- Parameter set
- Software update
- Mathematics module

The advanced version features an additional mathematics module for complex measuring tasks and parameter creation at the PC.

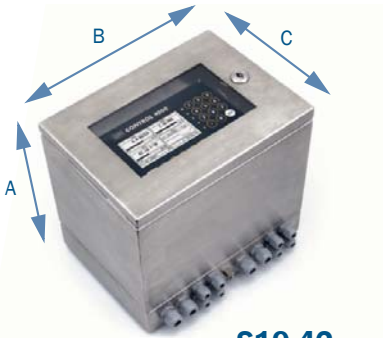

S19-42

Wall mount housing (IP65)
Material: stainless steel 1.4301 / SS304
A: 301 mm (11.9 in.)
B: 340 mm (13.4 in.)
C: 237 mm (9.4 in.)



B19-42

Wall mount housing (IP66)
Material: plastic (ABS)
A: 287 mm (11.3 in.)
B: 353 mm (13.9 in.)
C: 147 mm (5.8 in.)
D: 237 mm (9.4 in.)



T19-42

Table top housing (IP65)
Material: aluminum
A: 150 mm (5.9 in.)
B: 260 mm (10.2 in.)
C: 320 mm (12.6 in.)

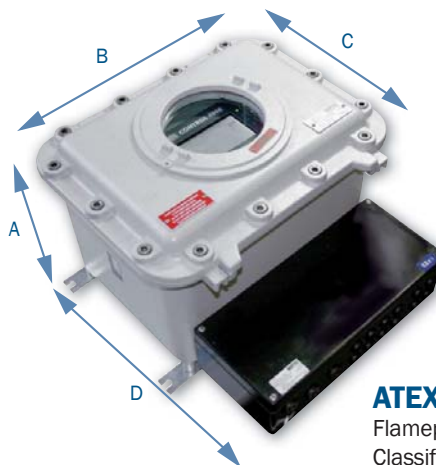

ATEX EX-D

Flameproof housing Ex d (IP65)
Classification: II 2(2) G Ex de [ia] II B T5
Approval: KEMA 08 ATEX 0123
Material: cast aluminum
A: 320 mm (12.6 in.)
B: 450 mm (17.7 in.)
C: 355 mm (14.0 in.)
D: 500 mm (19.7 in.)

Front-Kit

Front panel mounting (IP65 - front only)
(not shown)

Technical Data	C4000	C8000
Housing	19"-version for mounting in control cabinets 3 U / 42 HP - dimensions: W 213.0 mm (8.39 in.) H 128.4 mm (5.06 in.) D 230.0 mm (9.05 in.) - material: stainless steel / polyester / silicone / glass / diverse plastics - protection: front IP40 / rear IP20 (mains supply secured against accidental touching)	
Display	LCD graphic display black on white (240 x 128 pixel), LED background illuminated	
Operation	18-button keyboard	
System clock	accuracy approx. 1 minute/month (battery life approx. 15 years)	
LED	1 LED (green): power on 1 LED (red-flashing): system failure 3 LEDs (yellow): alarm I, II, III	1 LED (green): power on 1 LED (red-flashing): system failure
Data logger	4 parallel measuring values (ring buffer with approx. 25,000 data points x 4) (interval: 1/second - 1/hour)	8 parallel measuring values (ring buffer with approx. 12,500 data points x 8) (interval: 1/second - 1/hour)
Sensor-inputs	1 - 4 for optek photometric sensors n/a n/a	4 for optek photometric sensors 2 for optek conductivity sensors 2 for pH-probes (temperature compensated)
Sensor-inputs (explosion proof)	optional: 1 - 4 for optek photometric sensors (intrinsic safe)	n/a
mA-inputs	optional: 2 x 4 - 20 mA (functionally galvanically isolated) - accuracy: < 0.5 % - resolution: < 0.05 % - load: < 200 Ohm	n/a
Remote-inputs	optional: 7 x 24 V (19 ... 29 V DC), typically 6.0 mA for remote range setting, remote zero, remote hold	standard: 4 x 24 V (19 - 29 V DC), typically 6.0 mA for remote range setting, remote zero
Profibus PA interface	optional: Profibus PA profile, version 3.01, amendment 2 - voltage range: 9 ... 32 V DC - power consumption: 18 mA (functionally galvanically isolated)	n/a
Sensor lamp-outputs	1 or 2 lamp supply for optek photometric sensors 4.5 ... 8.5 V DC	1 lamp supply for optek photometric sensors 4.5 ... 7.8 V DC
mA-outputs	2 or 4 x 0/4 - 20 mA (NAMUR) (functionally galvanically isolated) - accuracy: < 0.5 % - resolution: < 0.05 % - load: < 600 Ohm	8 x 0/4 - 20 mA (NAMUR) (functionally galvanically isolated) - accuracy: < 0.5 % - resolution: < 0.05 % - load: < 600 Ohm
Relay-outputs	3 independent software-configurable relay contacts 0 - 50 V AC, 0 - 75 V DC, 0 - 2 A - for alarm or status feedback - initiation delay configurable: 0 - 999 sec.	n/a
Failsafe-output	1 SPDT contact to alarm in case of lamp or system failure (active) 0 - 50 V AC, 0 - 75 V DC, 0 - 2 A	
Serial communication	RS232 bi-directional interface on front panel (with software package optek PC-transfer) - up- and download of configuration, download of data logger content	
Cable lengths (sensor)	2, 3, 5, 10, 15, 20, 30 ... 100 m (7, 10, 16, 33, 49, 66, 98 ... 328 ft) cable length > 100 m on request up to 1,000 m (3,280 ft) sensors: AS56 / AS16: max: 50 m	2, 3, 5, 10, 15, 20, 30 m (7, 10, 16, 33, 49, 66, 98 ft)
Power supply	115 / 230 V AC, selectable (93.5 - 132 / 187 - 264 V AC, 47 - 64 Hz) or 24 V AC / DC (AC: 20.4 - 26.4 V AC, 47 - 64 Hz; DC: 20.4 - 28.8 V DC) - power consumption: < 50 VA	
Ambient conditions	temperature during operation (no direct sunlight): - converter: -10 - 55 °C (14 - 131 °F) - with optional stainless steel housing S19-42 (IP65): -20 - 45 °C (-4 - 113 °F) - with optional plastic housing B19-42 (IP66): -10 - 40 °C (14 - 104 °F) (C4000 only) - with optional Ex d housing (IP65): -20 - 40 °C (-4 - 104 °F) (C4000 only) temperature during transport (no direct sunlight) : -20 - 70 °C (-4 - 158 °F)	
Software languages	English, German, French, Spanish, Dutch, Portuguese, Russian	

10 | Optical Sensors Overview

Sensor Specifications							
	AS16	AS56	AF16	AF26	AF45	AF46	TF16
Basic Measuring principle:	①	①	②	③	④	⑤	⑥
Absorption of light - 1-channel	✓	✓	✓	✓	✓	✓	✓
Absorption of light - 2-channel	—	—	—	✓	—	✓	—
Scattering of light - 11°	—	—	—	—	—	—	✓
Basic Measuring ranges:							
CU / AU / OD / % Tr.	✓	✓	✓	✓	✓	✓	✓
ppm / FTU / EBC	—	—	—	—	—	—	✓
Wavelengths used:							
NIR (730 - 970 nm) - Turbidity	AS16-N	AS56-N	AF16-N	—	—	—	✓
VIS (385 - 1000 nm) - Color	—	—	AF16-F	✓	—	—	—
VIS (430 - 620 nm) - Color	AS16-F	AS56-F	AF16-F	✓	—	—	—
UV (254 - 313 nm)	—	—	—	—	✓	✓	—
Windows and OPL:							
Window material: Pyrex	—	—	✓	✓	—	—	✓
Window material: Sapphire	✓	✓	✓	✓	✓	✓	✓
OPL (optical path length) mm	1 - 40	5 / 10	1 - 1000	1 - 1000	1 - 160	1 - 160	40
Window gaskets (various)	n/a	n/a	✓	✓	✓	✓	✓
Process adaption:							
Armature in pipe	—	—	✓	✓	✓	✓	✓
Insertion through port	✓	✓	—	—	—	—	—
Process ratings:							
Max. pressure up to bar (psi)	20 (290)	10 (145)	100 (1450) pending on materials and design (higher on request)				
Max. temperature up to °C (°F) - continuously	100 (212)	90 (194)	120 (248)	120 (248)	70 (158)	70 (158)	120 (248)
Options:							
HT (high temperature) up to °C (°F) - continuously	—	—	240 (464)	240 (464)	120 (248)	120 (248)	240 (464)
VB (calibration adapter)	✓	—	✓	✓	✓	✓	—
EX-proof ATEX	—	—	✓	✓	✓	✓	✓
EX-proof FM	—	—	✓	✓	✓	✓	✓

Pressure and temperature ratings specified herein may be subject to limitations - see instruction manual.
 The appropriate choice of material for all wetted parts is the sole responsibility of the user.
 Data given are subject to changes without prior notice.

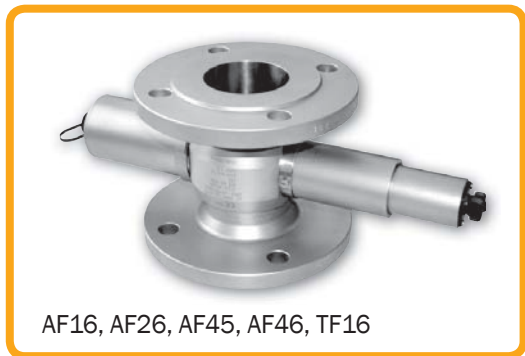

① **Probe AS16 / AS56**

VIS- and NIR-Absorption,
single channel concentration and
color measurement

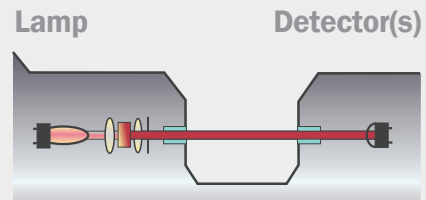

② **Sensor AF16**

VIS- and NIR-Absorption,
single channel concentration
and color measurement

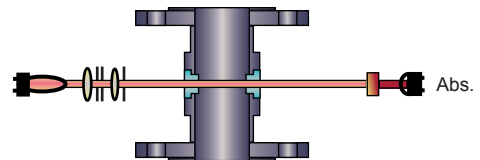

③ **Sensor AF26**

VIS-Absorption,
dual channel color measurement
with turbidity compensation

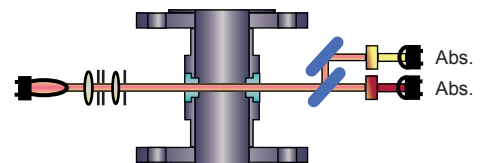

④ **Sensor AF45**

UV-Absorption,
single channel concentration measurement
with compensation of lamp intensity

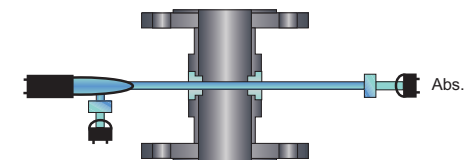

⑤ **Sensor AF46**

UV-Absorption,
dual channel concentration measurement
with compensation of lamp intensity

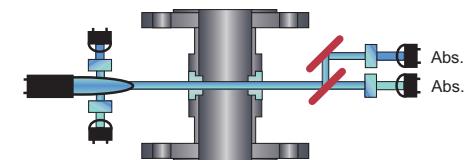

⑥ **Sensor TF16**

11° scattered light and NIR-Absorption
dual channel turbidity measurement

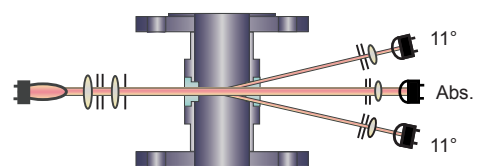

12 | Turbidity Sensors AF16-N/TF16-N

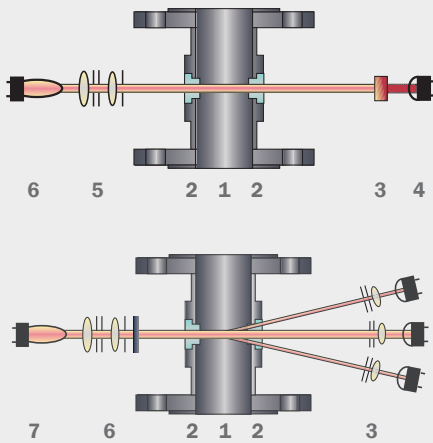

② Model AF16-N Single Channel Absorption (NIR)

- | | |
|-----------------|------------------------|
| 1 Sensor body | 2 Windows |
| 3 Filter | 4 Measurement detector |
| 5 Optics module | 6 Lamp module |

⑥ Model TF16-N Dual Channel Scattered Light (11°)

- | | |
|-----------------------|----------------------|
| 1 Sensor body | 2 Windows |
| 3 Focusing optics | 4 Detector 0° (Abs.) |
| 5 Eight 11° detectors | 6 Optics module |
| 7 Lamp module | |

Models AF16-N and TF16-N are high precision turbidity sensors for use in various industries. The sensors are designed for inline operation and provide accurate concentration measurements with remarkable repeatability, linearity and resolution.

Modular construction of the sensors offers maximum flexibility in adapting to various process needs. Options include electro-polished sensor bodies, hazardous location (explosion-proof) capability, chemical resistant materials (sapphire windows, titanium, Hastelloy, etc.) and high temperature or high pressure versions.

AF16-N (NIR-Absorption / Turbidity)

A special tungsten lamp produces a constant light beam that passes through the process medium. The attenuation of the light intensity, caused by absorption and/or scattering by dissolved and undissolved substances, is detected by a sealed silicon photodiode.

The AF16-N uses light from 730 - 970 nm (NIR) to measure solids concentration independent from color or color changes. Pending on the optical path length, measuring ranges from high % (OPL = 1 mm) to 0 - 100 ppm (OPL = 160 mm) are possible.

TF16-N (Scattered Light / Turbidity)

Light scattered from particles (trace suspended solids, undissolved liquids or gas bubbles) in the medium is detected by eight hermetically sealed silicon photodiodes at an angle of 11°. At the same time, the unscattered light is detected by a reference photodiode (comparable to an AF16-N). This unique dual channel design compensates for disturbances of the carrier medium. The sensor can be calibrated in ppm (DE), EBC or FTU and measures extremely low particle sizes and concentrations. Additionally, high particle concentrations can be monitored independent of color at the direct light detector.

OPL

Special optical windows are made from a single crystal sapphire, providing superior resistance to all abrasive and corrosive media. With the appropriate

choice of sensor bodies and windows in various lengths, the optimal OPL (optical path length = distance between the windows) can be achieved to meet the measurement requirements, i.e. low/high measuring ranges at highest resolution.

NIST-traceable

NIST-traceable calibration accessories (AF16-N only) provide absolute measurement confidence (for details refer to page 23).

Typical applications:

- Separator control, pulp concentration (AF16-N)
- Filter control, oil in water (TF16-N)

See our **TOP 5 brochures for applications in your industry.**



optek TF16-EX-HT-N
Scattered Light Dual Channel
Turbidity Sensor



Turbidity Sensors AF16-N/TF16-N | 13

Technical Data	AF16-N (Turbidity)	TF16-N (Turbidity)
Measurement		
Measurement principle	1- Channel Absorption of light	1- Channel Absorption of light and 2- Channel Scattering of light (11°)
Measurement wavelength	730 nm - 970 nm	730 nm - 970 nm
Detector(s)	1 silicon photodiode (hermetically sealed)	1 silicon photodiode (hermetically sealed) (Abs.) 8 silicon photodiodes (hermetically sealed) (11°)
Measuring range NIR-Absorption	any measuring range between 0 - 0.05 to 6 CU 0 - 50 to 40,000 ppm (DE) 0 - 20 to 16,000 FTU 0 - 5 to 4,000 EBC	any measuring range between 0 - 0.05 to 5 CU 0 - 50 to 8,000 ppm (DE) 0 - 20 to 3,200 FTU 0 - 5 to 800 EBC
Measuring range Scattered Light (11°)	n/a	any measuring range between 0 - 0.5 to 500 ppm (DE) 0 - 0.2 to 200 FTU 0 - 0.05 to 50 EBC (higher (i.e. 100 EBC) with reduced resolution, accuracy)
Optical path length	1 - 1000 mm	40 mm standard (10 - 60 mm with reduced accuracy)
Calibration	Abs.: CU (concentration units) application specific calibration	Abs.: CU (concentration units) application specific calibration basic calibration 11°: in ppm (DE) / FTU / EBC
Light source	special incandescent tungsten lamp 5.0 V DC, 775 mA typical life span: 3 to 5 years (25,000 to 40,000 hours)	
Resolution	< ± 0.05 % of respective measuring range	
Repeatability	< ± 0.5 % of respective measuring range (scattered light < ± 0.3 %)	
Linearity	< ± 1 % of respective measuring range (specific to application)	
Protection	all optical parts have an IP rating of IP65 or higher	
Sensor body		
Material	Stainless steel 1.4435 (SS 316L), 1.4539, 1.4571 (SS 316Ti), 1.4462, Titanium 3.7035 (Grade 2), Hastelloy 2.4602 (C22), Plastic TFM4215, PVC, ... others on request	
Line size	1/4 in. to 6 in. (DN 6 to DN 150), ... others on request	
Process connection	Flanges (ASME, DIN, JIS), Clamps (TC, ISO, DIN), Female Threads (NPT, DIN), Sanitary Threads (DIN 11851), Tube Ends (DIN, ISO, OD), Varivent, ... others on request	
Process pressure	10 mbar to 100 bar (0.15 psi to 1450 psi) - higher on request depending on process connection, materials and design	
Windows	1-Pyrex®, 2-Sapphire, 3-Sapphire Biotech	
Window gaskets	Silicone (FDA), Viton® (FDA), EPDM (FDA / USP Class VI), Kalrez® 4079, ... others on request	
Temperature ratings		
Process temperature	permanent: 0 - 120 °C (32 - 248 °F) / peak 15 min/day: 0 - 150 °C (32 - 302 °F)	
Process temperature OPTION HT	permanent: -30 - 240 °C (-22 - 464 °F) / peak 15 min/day: -30 - 260 °C (-22 - 500 °F)	
Process temperature OPTION EX	permanent: -30 - 120 °C (-22 - 248 °F) / peak 15 min/day: -30 - 150 °C (-22 - 302 °F)	
Process temperature OPTION EX-HT	permanent: -30 - 240 °C (-22 - 464 °F) / peak 15 min/day: -30 - 260 °C (-22 - 500 °F)	
Ambient temperature	operation: 0 - 40 °C (32 - 104 °F) operation: -30 - 40 °C (-22 - 104 °F) with options HT / EX / EX-HT transport: -20 - 70 °C (-4 - 158 °F)	
Explosion proof		
Ex-proof	none	
Ex-proof OPTION EX (EN-D)	Sensor assembly in ex-proof version accor. ATEX (EN-D) - Approval: DMT ATEX E 176	
Ex-proof OPTION EX (FM-D)	Sensor assembly in ex-proof version accor. FM (FM-D) - Approval: FMG J. I. 3013884	
Calibration		
Calibration adapter	none	n/a
Calibration adapter OPTION VA	Filter adapter FH01 (lamp side) for calibration filter used for sensor verification	n/a
Calibration adapter OPTION VB - recommended -	Filter adapter FH03 (detector side) for calibration filter used for sensor verification	n/a

Pressure and temperature ratings specified herein may be subject to limitations - see instruction manual.
The appropriate choice of material for all wetted parts is the sole responsibility of the user.
Data given are subject to changes without prior notice.

14 | Color Sensors AF16-F/AF26

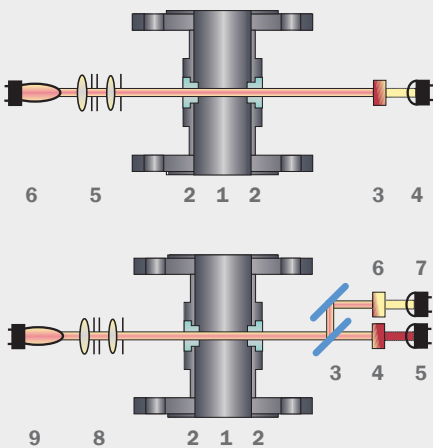

2 Model AF16-F Single Channel Absorption (VIS)

- | | |
|-----------------|------------------------|
| 1 Sensor body | 2 Windows |
| 3 Filter | 4 Measurement detector |
| 5 Optics module | 6 Lamp module |

3 Model AF26 Dual Channel Absorption (VIS-NIR)

- | | |
|--------------------------|-----------------|
| 1 Sensor body | 2 Windows |
| 3 Beam splitter | 4 Filter A |
| 5 Measurement detector A | 6 Filter B |
| 7 Measurement detector B | 8 Optics module |
| 9 Lamp module | |

Models AF16-F and AF26 are high precision color sensors used to measure color or color changes in various industries. The sensors are designed for inline operation and provide accurate concentration measurements with remarkable repeatability, linearity and resolution.

Modular construction of the sensors offers maximum flexibility in adapting to various process needs. Options include electro-polished sensor bodies, hazardous location (explosion-proof) capability, chemical resistant materials (sapphire windows, titanium, Hastelloy, etc.) and high temperature or high pressure versions.

VIS-Absorption (Color)

A special tungsten lamp produces a constant light beam that passes through the process medium. The attenuation of the light intensity, caused by absorption and/or scattering by dissolved and undissolved substances, is detected by sealed silicon photodiodes.

At a specific wavelength in the visible range (385 - 670 nm) there is a loss of light as a result of an increase in color depth. optek sensors measure in various color scales such as Hazen, APHA, ASTM, EBC, Gardner, Saybolt, and many more. Also, many dissolved substances in liquids can be precisely

monitored using color measurements. For instance, increasing iron or nickel contents result in a yellow liquid.

OPL

Special optical windows are made from a single crystal sapphire, providing superior resistance to all abrasive and corrosive media. With the appropriate choice of sensor bodies and windows in various lengths, the optimal OPL (optical path length = distance between the windows) can be achieved to meet the measurement requirements, i.e. low/high measuring ranges at highest resolution.

Dual Wavelengths

Selected combinations of optical filters make it possible to focus on specific wavelengths ensuring suitable adaptation to the application. While the AF16-F uses one wavelength, an AF26 is equipped with an internal beam splitter making it possible to measure two wavelengths simultaneously.

Connected to optek Control 4000 or Control 8000 converters, the second wavelength can be used to compensate for (varying) background turbidity and any lamp intensity variation to assure the highest level of precision and long-term performance. Combined with a long optical path length, even the smallest color changes can be measured.

NIST-traceable

NIST-traceable calibration accessories provide absolute measurement confidence (for details refer to page 23).

Typical applications:

- Monitoring of various color scales
0 - 10 to 0 - 500 Hazen,
0 - 1 to 0 - 8 ASTM etc.
- Measuring various concentrations
0 - 100 mg/l chlorine,
0 - 5 mg/l iron in hydrochloric acid,
0 - 100 % chlorine gas

See our TOP 5 brochures for applications in your industry.

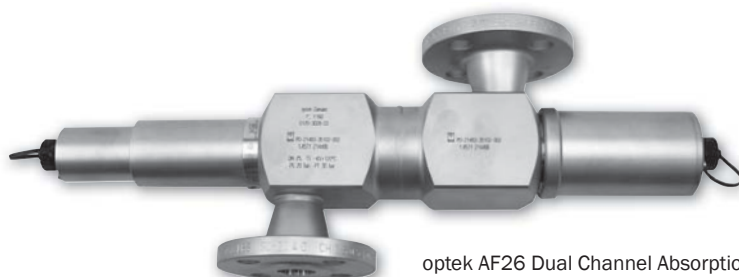

optek AF26 Dual Channel Absorption Sensor



Technical Data	AF16-F (Color)	AF26 (Color)
Measurement		
Measurement principle	1- Channel Absorption of light	2- Channel Absorption of light
Measurement wavelength(s)	385, 400, 415, 430, 470, 525, 550, 620, 670, 700, 750, 800, 1000 nm, others on request	385/430, 385/550, 400/550, 400/620, 415/550, 420/700, 430/525, 430/620, 430/700, 460/620, 470/620, 470/700, 525/620, 525/700, 525/750, 550/620, 550/800, 620/660, 620/800, 670/550, 670/750, 1000/800 nm, others on request
Detector(s)	1 silicon photodiode (hermetically sealed)	2 silicon photodiodes (hermetically sealed)
Measuring range	any measuring range between 0 - 0.05 to 2.8 CU (dependent on used filter) (contact product specialist for application specific ranges)	any measuring range between 0 - 0.05 to 3 CU (dependent on used filter) (contact product specialist for application specific ranges)
Optical path length	1 - 1000 mm	
Calibration	CU (concentration units) application specific calibration	
Light source	special incandescent tungsten lamp 5.0 V DC, 775 mA typical life span: 3 to 5 years (25,000 to 40,000 hours)	
Resolution	< ± 0.05 % of respective measuring range	
Repeatability	< ± 0.5 % of respective measuring range	
Linearity	< ± 1 % of respective measuring range (specific to application)	
Protection	all optical parts have an IP rating of IP65 or higher	
Sensor body		
Material	Stainless steel 1.4435 (SS 316L), 1.4539, 1.4571 (SS 316Ti), 1.4462, Titanium 3.7035 (Grade 2), Hastelloy 2.4602 (C22), Plastic TFM4215, PVC, ... others on request	
Line size	1/4 in. to 6 in. (DN 6 to DN 150), ... others on request	
Process connection	Flanges (ASME, DIN, JIS), Clamps (TC, ISO, DIN), Female Threads (NPT, DIN), Sanitary Threads (DIN 11851), Tube Ends (DIN, ISO, OD), Varivent, ... others on request	
Process pressure	10 mbar to 100 bar (0.15 psi to 1450 psi) - higher on request depending on process connection, materials and design	
Windows	1-Pyrex®, 2-Sapphire, 3-Sapphire Biotech	
Window gaskets	Silicone (FDA), Vitor® (FDA), EPDM (FDA / USP Class VI), Kalrez® 4079, ... others on request	
Temperature ratings		
Process temperature	permanent: 0 - 120 °C (32 - 248 °F) / peak 15 min/day: 0 - 150 °C (32 - 302 °F)	
Process temperature OPTION HT	permanent: -30 - 240 °C (-22 - 464 °F) / peak 15 min/day: -30 - 260 °C (-22 - 500 °F)	
Process temperature OPTION EX	permanent: -30 - 120 °C (-22 - 248 °F) / peak 15 min/day: -30 - 150 °C (-22 - 302 °F)	
Process temperature OPTION EX-HT	permanent: -30 - 240 °C (-22 - 464 °F) / peak 15 min/day: -30 - 260 °C (-22 - 500 °F)	
Ambient temperature	operation: 0 - 40 °C (32 - 104 °F) operation: -30 - 40 °C (-22 - 104 °F) with options HT / EX / EX-HT transport: -20 - 70 °C (-4 - 158 °F)	
Explosion proof		
Ex-proof	none	
Ex-proof OPTION EX (EN-D)	Sensor assembly in ex-proof version accor. ATEX (EN-D) - Approval: DMT ATEX E 176	
Ex-proof OPTION EX (FM-D)	Sensor assembly in ex-proof version accor. FM (FM-D) - Approval: FMG J. I. 3013884	
Calibration		
Calibration adapter	none	
Calibration adapter OPTION VA	Filter adapter FH01 (lamp side) for calibration filter used for sensor verification	
Calibration adapter OPTION VB - recommended -	Filter adapter FH03 (detector side) for calibration filter used for sensor verification	

Pressure and temperature ratings specified herein may be subject to limitations - see instruction manual.
The appropriate choice of material for all wetted parts is the sole responsibility of the user.
Data given are subject to changes without prior notice.

16 | UV Sensors AF45/AF46

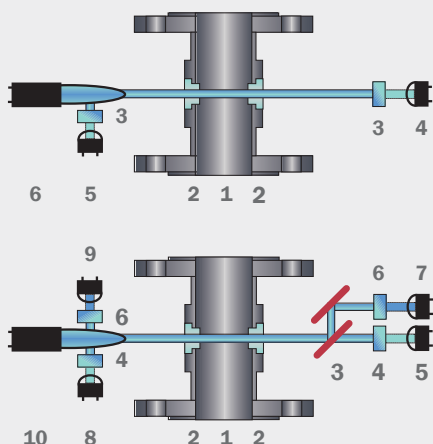

4 Model AF45 Single Channel Absorption (UV)

- | | |
|----------------------|-------------------------|
| 1 Sensor body | 2 Windows |
| 3 Filter | 4 Measurement detector |
| 5 Reference detector | 6 Lamp module (mercury) |

5 Model AF46 Dual Channel Absorption (UV)

- | | |
|--------------------------|--------------------------|
| 1 Sensor body | 2 Windows |
| 3 Beam splitter | 4 Filter A |
| 5 Measurement detector A | 6 Filter B |
| 7 Measurement detector B | 8 Reference detector A |
| 9 Reference detector B | 10 Lamp module (mercury) |

Models AF45 and AF46 are high precision UV Absorption sensors for use in the biotech and chemical industries. The sensors are designed for inline operation and provide accurate concentration measurements with remarkable repeatability, linearity and resolution.

Modular construction of the sensors offers maximum flexibility in adapting to various process needs. Options include electro-polished sensor bodies, hazardous location (explosion-proof) capability, chemical resistant materials (sapphire windows, titanium, Hastelloy, etc.) and high temperature or high pressure versions.

UV-Absorption

A special mercury lamp produces a constant light beam that passes through the process medium. The attenuation of the light intensity, caused by absorption and/or scattering by dissolved and undissolved substances, is detected by sealed silicon photodiodes.

In addition, the light intensity of the lamp itself is measured by sealed silicon photodiodes using the same filter as the measurement wavelength. The sealed silicon photodiodes also compensate for any variances in lamp intensity, assuring the highest level of precision and long-term performance. Specific lamp design and capability of

optek converters operating with lowest photo-currents provide a prolonged life time at the lowest cost of ownership.

OPL

Special optical windows are made from a single crystal sapphire, providing superior resistance to all abrasive and corrosive media. With the appropriate choice of sensor bodies and windows in various lengths, the optimal OPL (optical path length = distance between the windows) can be achieved to meet the measurement requirements, i.e. low/high measuring ranges at highest resolution.

Dual Wavelengths

Selected combinations of optical filters make it possible to focus on specific wavelengths. Different peak wavelengths are available with a variety of bandwidth options ensuring suitable adaptation to the application.

While the AF45 uses one wavelength,

an AF46 is equipped with an internal beam splitter making it possible to measure two wavelengths simultaneously. Connected to optek Control 4000 or Control 8000 converters, a wide dynamic range is possible to measure at high and low values with one sensor in one setup. Thus ensuring minimal hold-up volume and installation cost.

NIST-traceable

NIST-traceable calibration accessories provide absolute measurement confidence (for details refer to page 23).

Typical applications:

- Monitoring of chromatographic columns (i.e. protein concentration)
- Measuring concentrations of aromatics

See our TOP 5 brochures for applications in your industry.



optek AF45-VB
Single Channel UV Absorption Sensor
with calibration option

Technical Data	AF45 (UV)	AF46 (UV)
Measurement		
Measurement principle	1- Channel Absorption of light	2- Channel Absorption of light
Measurement wavelength(s)	254-13, 280-09, 280-13, 290-13, 300-13, 313-13 nm, ... others on request	254-13 / 280-13, 254-13 / 313-13, 280-09 / 300-05, 280-09 / 300-13, 280-09 / 313-13, 280-13 / 300-13, 280-13 / 313-13, 290-13 / 313-13 nm, ... others on request
Measuring detector(s)	1 silicon photodiode (hermetically sealed)	2 silicon photodiodes (hermetically sealed)
Reference detector(s)	1 silicon photodiode (hermetically sealed)	2 silicon photodiodes (hermetically sealed)
Measuring range	any measuring range between 0 - 0.05 to 3 CU (dependent on used filter / OPL) (contact product specialist for application specific ranges)	any measuring range between 0 - 0.05 to 2 CU (dependent on used filter / OPL) (contact product specialist for application specific ranges)
Optical path length	1 - 160 mm	
Calibration	CU (concentration units) application specific calibration	
Light source	low pressure mercury lamp typical life span: 1 to 2 years (8,000 to 16,000 hours)	
Resolution	< ± 0.05 % of respective measuring range	
Repeatability	< ± 0.5 % of respective measuring range	
Linearity	< ± 1 % of respective measuring range (specific to application)	
Protection	all optical parts have an IP rating of IP65 or higher	
Sensor body		
Material	Stainless steel 1.4435 (SS 316L), 1.4539, 1.4571 (SS 316Ti), 1.4462, Titanium 3.7035 (Grade 2), Hastelloy 2.4602 (C22), Plastic TFM4215, PVC, ... others on request	
Line size	1/4 in. to 6 in. (DN 6 to DN 150), ... others on request	
Process connection	Flanges (ASME, DIN, JIS), Clamps (TC, ISO, DIN), Female Threads (NPT, DIN), Sanitary Threads (DIN 11851), Tube Ends (DIN, ISO, OD), Varivent, ... others on request	
Process pressure	10 mbar to 100 bar (0.15 psi to 1450 psi) - higher on request depending on process connection, materials and design	
Windows	2-Sapphire, 3-Sapphire Biotech (do not use Pyrex®)	
Window gaskets	Viton® (FDA), EPDM (FDA / USP Class VI), Kalrez® 4079, ... others on request (do not use Silicone)	
Temperature ratings		
Process temperature	permanent: 0 - 70 °C (32 - 158 °F) / peak 15 min/day: 0 - 135 °C (32 - 275 °F)	
Process temperature OPTION HT	permanent: -30 - 120 °C (-22 - 248 °F) / peak 15 min/day: -30 - 150 °C (-22 - 302 °F)	
Process temperature OPTION EX	permanent: -30 - 70 °C (-22 - 158 °F) / peak 15 min/day: -30 - 135 °C (-22 - 275 °F)	
Process temperature OPTION EX-HT	permanent: -30 - 120 °C (-22 - 248 °F) / peak 15 min/day: -30 - 150 °C (-22 - 302 °F)	
Ambient temperature	operation: 0 - 40 °C (32 - 104 °F) operation: -30 - 40 °C (-22 - 104 °F) with options HT / EX / EX-HT transport: -20 - 70 °C (-4 - 158 °F)	
Explosion proof		
Ex-proof	none	
Ex-proof OPTION EX (EN-D)	Sensor assembly in ex-proof version accor. ATEX (EN-D) - Approval: DMT ATEX E 176	
Ex-proof OPTION EX (FM-D)	Sensor assembly in ex-proof version accor. FM (FM-D) - Approval: FMG J. I. 3013884	
Calibration		
Calibration adapter	none	
Calibration adapter OPTION VB	Filter adapter FH03 (detector side) for calibration filter used for sensor verification	

Pressure and temperature ratings specified herein may be subject to limitations - see instruction manual.
The appropriate choice of material for all wetted parts is the sole responsibility of the user.
Data given are subject to changes without prior notice.

18 | Probe Sensors AS16/AS56

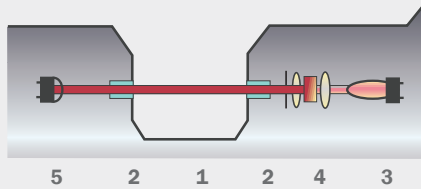

① Model AS16 (AS56) Single Channel Absorption

- 1 OPL
- 2 Windows
- 3 Lamp module
- 4 Optics modules (incl. filter)
- 5 Detector module

No window gaskets used

Models AS16 and AS56 are high precision sensors measuring turbidity (AS16-N and AS56-N) or color (AS16-F and AS56-F) for use in various industries. The sensors are designed for inline operation and provide accurate concentration measurements with remarkable repeatability, linearity and resolution.

AS16

The AS16 series offers the high-end range of optek probe sensors. A wide selection of different optical path lengths and insertion depths combined with optional calibration filters and electro-polished stainless steel meet the requirements of the Biotechnology industry.

AS56

The AS56, based on the same design as the AS16 with seal-less window construction, is typically used in food and beverage applications. Limited variations allow cost effective measurement (i.e. phase separation).

NIR-Absorption (Turbidity) VIS-Absorption (Color)

A special tungsten lamp produces a constant light beam that passes through the process medium. The attenuation of the light intensity, caused by absorption and/or scattering by dissolved and undissolved substances, is detected by a sealed silicon pho-

todiode. AS16-N (AS56-N) uses light from 730 - 970 nm to measure solids concentration independent from color or color changes (i.e. yeast concentration in beer during tank draining). AS16-F (AS56-F) uses a specific wavelength in the visible spectrum to measure color in liquids with little or no turbidity (i.e. beer in water during phase change).

OPL

Special optical windows are made from a single crystal sapphire, providing superior resistance to all abrasive and corrosive media. optek superior manufacturing techniques allow mounting the windows without gaskets or glue for life time without maintenance. The appropriate choice of the optimal OPL (optical path length = distance between the windows) supports all measurement requirements, i.e. low/high measuring ranges at highest resolution.

NIST-traceable

NIST-traceable calibration accessories (AS16 only) provide absolute measurement confidence (for details refer to page 23).

Typical applications:

- Cell density in fermentation (AS16-N)
- Milk/water phase separation (AS56-N)
- Beverage blending (AS16-F)
- Beer/water phase separation (AS56-F)

See our TOP 5 brochures for applications in your industry.



optek AS16-N Single Channel Absorption Probe



optek AS16-VB-N Single Channel Absorption Probe with calibration option



Technical Data	AS16	AS56
Measurement		
Measurement principle	1- Channel Absorption of light	
Detector	1 silicon photodiode (hermetically sealed)	
Measurement wavelength	<ul style="list-style-type: none"> AS16-N: 730 - 970 nm AS16-F: 430, 550 or 620 nm 	<ul style="list-style-type: none"> AS56-N: 730 - 970 nm AS56-F: 430 nm
Measuring range	AS16-N: any measuring range between 0 - 0.05 to 6 CU AS16-F: any measuring range between 0 - 0.05 to 2 CU (depending on wavelength)	AS56-N: any measuring range between 0 - 0.05 to 4 CU AS56-F: any measuring range between 0 - 0.05 to 1.5 CU
Optical path length	1, 5, 10, 20 or 40 mm	5 or 10 mm
Calibration	CU (concentration units) application specific calibration	
Light source	special incandescent tungsten lamp 5.0 V DC, 775 mA typical life span: 3 to 5 years (25,000 to 40,000 hours)	special incandescent tungsten lamp 5.0 V DC, 450 mA typical life span: 3 to 5 years (25,000 to 40,000 hours)
Resolution	< ± 0.05 % of respective measuring range	< ± 0.5 % of respective measuring range
Repeatability	< ± 0.5 % of respective measuring range	< ± 1.0 % of respective measuring range
Linearity	< ± 1 % of respective measuring range (specific to application)	< ± 2 % of respective measuring range (specific to application)
Protection	all optical parts have an IP rating of IP65 or higher	
Process adaption		
Material	wetted parts: stainless steel 1.4435 (SS 316 L) dF < 1 %, BN2 surface: electro-polished Ra < 0.4 µm housing: stainless steel 1.4571 (SS 316 Ti)	wetted parts: stainless steel 1.4435 (SS 316 L) surface: electro-polished Ra < 0.8 µm housing: stainless steel 1.4571 (SS 316 Ti)
Port connection	thread G1-1/4 in., ISO 228/1 for port AS25 (similar Ingold-port) diameter: 25 mm (D= 25 H7) O-ring groove for 30 mm and for 60 mm port length	
Port gasket	O-ring 18.64 x 3.53 mm EPDM (FDA / USP Class VI)	
Insertion depth	35 mm (1.38 in.) + OPL at a port length of 60 mm (2.36 in.)	35 mm (1.38 in.) + OPL at a port length of 60 mm (2.36 in.)
	135 mm (5.31 in.) + OPL at a port length of 60 mm (2.36 in.)	n/a
Process pressure	10 mbar to 20 bar (0.15 psi to 290 psi)	10 mbar to 10 bar (0.15 psi to 145 psi)
Windows	sapphire (seal-less)	
Window gaskets	n/a	
Installation accessories	weld-in ports, Varivent adapter (50.00), clamp adapter (1.5 and 2.0 in.) optek T-pieces DIN 11850 (DN50 - DN100), optek T-pieces OD (BS4821-1) (2.0 - 4.0 in.)	
Temperature ratings		
Process temperature	permanent: 0 - 100 °C (32 - 212 °F) peak 60 min/day: 0 - 150 °C (32 - 302 °F)	permanent: 0 - 90 °C (32 - 194 °F) peak 60 min/day: 0 - 100 °C (32 - 212 °F)
Ambient temperature	operation: 0 - 40 °C (32 - 104 °F) transport: -20 - 70 °C (-4 - 158 °F)	
Calibration		
Calibration adapter	none	n/a
Calibration adapter OPTION VB	Filter adapter FH03 for calibration filter used for sensor verification	n/a

Pressure and temperature ratings specified herein may be subject to limitations - see instruction manual.
 The appropriate choice of material for all wetted parts is the sole responsibility of the user.
 Data given are subject to changes without prior notice.

20 | Conductivity Sensor ACF60



- Patented six-electrode design reduces sensitivity to fouling and polarization
- Wide measuring range: 0 - 10 $\mu\text{S/cm}$ up to 0 - 850 mS/cm
- Integrated Pt1000 temperature sensor
- No O-rings or epoxy - suitable for CIP/SIP

SIX-Electrodes

The ACF60 conductivity sensor features a superior six-electrode, four-pole design. The patented arrangement of the four current electrodes around the two potential electrodes results in a reliable and precise measurement. This unique design also provides greatly reduced sensitivity to sensor fouling and polarization. The combination of optek C8000 universal converter and ACF60 conductivity sensors allow a wide dynamic range from 0 - 10 $\mu\text{S/cm}$ up to 0 - 850 mS/cm with the same sensor.

Temperature Measurement

The integrated Pt1000 platinum RTD in the tip of the ACF60 sensor provides fast-response temperature measurement for compensation, and can be displayed and transmitted from the C8000 converter.

Sanitary Design

Designed for ultra-sterility, the six electrodes are sealed in the FDA (USP class VI) compliant PEEK sensor tip without the use of O-rings or epoxy. Mounted in an optek inline sensor body the design ensures smooth and unrestricted flow of all process fluids with minimized hold-up and hydrostatic shear. The ACF60 sensor is suitable for CIP/SIP applications.

Typical applications:

- Monitoring of CIP processes
- Measuring ultrapure water

See our **TOP 5 brochures for applications in your industry.**



ACF60
Conductivity sensor

Technical Data	ACF60	
Material	probe body: PEEK (FDA, USP class VI)	
Electrodes	stainless steel 1.4435 (SS 316L), dF < 1%, BN2	
Port-gaskets	O-ring: EPDM (FDA / USP Class VI), ... others on request	
Line size	1/4 in. to 6 in. (DN 6 to DN 150), ... others on request	
Process pressure	20 bar (290 psi) - 50 °C (122 °F) 10 bar (145 psi) - 100 °C (212 °F) 4 bar (58 psi) - 135 °C (275 °F)	
Process temperature	permanent: -10 - 90 °C (14 - 194 °F) peak 30 min/day: -10 - 135 °C (14 - 275 °F)	
Ambient temperature	operation: -10 °C - 40 °C (14 °F - 104 °F) transport: -20 °C - 70 °C (-4 °F - 158 °F)	
Temperature sensor	integrated Pt1000 RTD (IEC Class A) accuracy: ± 0.25 °C at 25 °C (77 °F)	
Protection	all parts have an IP rating of IP65 or higher	
Measuring range	any measuring range between 0 - 10 $\mu\text{S/cm}$ to 850 mS/cm	
	Accuracy	Repeatability
0 - 10 $\mu\text{S/cm}$	calibrated: ± 1 % of measuring value ± 0.2 $\mu\text{S/cm}$ uncalibrated: ± 3 % of measuring value ± 0.2 $\mu\text{S/cm}$	± 0.5 %
0 - 250 mS/cm	calibrated: ± 1 % of measuring value ± 0.2 $\mu\text{S/cm}$ uncalibrated: ± 3 % of measuring value ± 0.2 $\mu\text{S/cm}$	± 0.5 %
250 - 500 mS/cm	calibrated: ± 2 % of measuring value ± 0.2 $\mu\text{S/cm}$ uncalibrated: ± 6 % of measuring value ± 0.2 $\mu\text{S/cm}$	± 1 %
500 - 850 mS/cm	calibrated: ± 5 % of measuring value ± 0.2 $\mu\text{S/cm}$ uncalibrated: ± 12 % of measuring value ± 0.2 $\mu\text{S/cm}$	± 3 %

Pressure and temperature ratings specified herein may be subject to limitations - see instruction manual. The appropriate choice of material for all wetted parts is the sole responsibility of the user. Data given are subject to changes without prior notice.



- 12-degree electrode orientation provides improved performance
- pH electrode solution ground allows inline diagnostics
- Designed to enhance flow and minimize hold-up volume
- Suitable for most Ø 12 x 120 mm pH-electrodes

12 Degree

The optek PF12 pH electrode adapter is designed to mount pH electrodes at the optimal angle of 12 degrees. This allows the sensor to use electrolyte-filled glass electrodes and improves the functionality and life time of the pH probes. The PF12 electrode adapter is compatible with a broad variety of pH electrodes.

Solution Ground

The PF12 is equipped with a solution earth (ground) connection mounted to the Sensor body, allowing the use of pH electrodes that incorporate differential pH input techniques. Additionally, the solution earth connection provides a highly stable measurement while enabling sensor diagnostics including low glass impedance, out-of sample, and broken electrode/cable warnings.

Sanitary Design

Mounted in an optek inline sensor body the design of the PF12 ensures smooth and unrestricted flow of all process fluids. The PF12 meets sterility requirements and is compatible with CIP/SIP while minimizing hold-up volume and hydrostatic shear.



PF12
pH electrode holder



ACF60

PF12

pH and conductivity measurement combined for low hold-up volume

line size	volume	volume
	cond. only	pH + cond.
0.25 in.	< 22 ml	< 41 ml
0.50 in.	< 26 ml	< 44 ml
0.75 in.	< 34 ml	< 52 ml
1.00 in.	< 48 ml	< 65 ml

Technical Data	PF12
Material	Stainless steel 1.4435 (SS 316L), dF < 1 %, BN2
Surface	electro polished (Ra < 0.4 µm)
Solution ground	female SA483 for solution ground plug
Line size	1/4 in. to 6 in. (DN 6 to DN 150), ... others on request
Electrode types	suitable for wide variety of electrodes with dimensions Ø 12 x 120 mm, PG 13.5 thread
Process temperature	-10 °C - 135 °C (14 °F - 275 °F)
Process pressure	6 bar (87 psi)

Pressure and temperature ratings specified herein may be subject to limitations - see instruction manual. The appropriate choice of material for all wetted parts is the sole responsibility of the user. Data given are subject to changes without prior notice.

22 | Sensor Body (Armature)

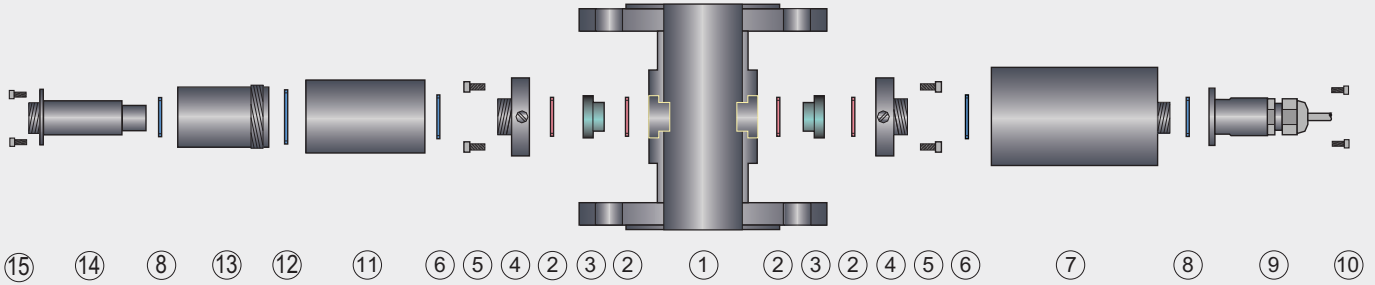

Description AF26:

- 1 Sensor body ¼ in. to 6 in. (DN 6 to DN 150)
- 2 O-ring (EPDM, Viton®, Kalrez® etc.)
- 3 Window (Sapphire, Pyrex®)
- 4 Window ring M24 (1.4571 / 316 Ti)
- 5 8 Screws with washer
- 6 O-ring (Viton®)
- 7 Detector module AF26
- 8 O-ring (EPDM, Viton®, Kalrez® etc.)
- 9 SS-plug protection (1.4571 / 316 Ti)
- 10 4 Screws (M3 x 6)
- 11 Optics module AF26
- 12 O-ring 31,47 x 1,78 mm
- 13 Optical housing OP06 (1.4571 / 316 Ti)
- 14 Lamp module AF26
- 15 4 Screws (M3 x 6)

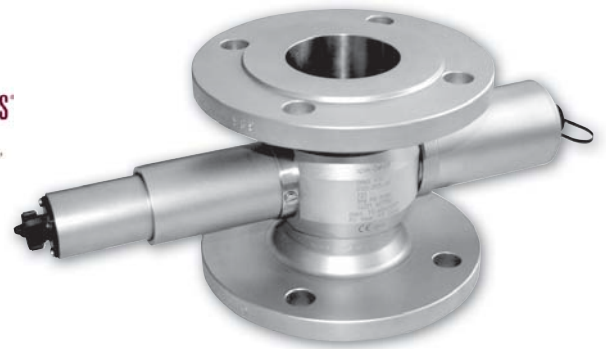

Sensor body - For all variations and details see separate sensor body datasheet.

Material	Stainless steel 1.4435 (SS 316L), 1.4539, 1.4571 (SS 316Ti), 1.4462, Titanium 3.7035 (Grade 2), Hastelloy 2.4602 (C22), Plastic TFM4215, PVC, ... others on request
Line size	1/4 in. to 6 in. (DN 6 to DN 150), ... others on request
Process connection	Flanges (ASME, DIN, JIS), Clamps (TC, ISO, DIN), Female Threads (NPT, DIN), Sanitary Threads (DIN 11851), Tube Ends (DIN, ISO, OD), Varivent, ... others on request
Process pressure	10 mbar to 100 bar (0.15 psi to 1450 psi) - higher on request depending on process connection, materials and design
Windows	1-Pyrex®, 2-Sapphire, 3-Sapphire Biotech
Window gaskets	Silicone (FDA), Viton® (FDA), EPDM (FDA / USP Class VI), Kalrez® 4079, ... others on request



Windows available in different lengths for OPL (optical path length) adjustment.



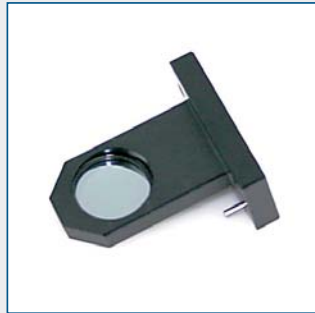

optek calibration accessories have been specially designed for nonintrusive calibration and verification of optek systems.

UV Sensors

Three series of solid filters are available to ensure confidence in measurements. The UV-L filter series is used to calibrate photometric accuracy and linearity. The UV-B filter series verifies integral blocking and the UV-S filter series tests for long term stability of the sensor.

VIS/NIR Sensors

A special series of solid filters is available for each wavelength (range) to ensure best measurement performance. The calibration filters are used to calibrate photometric accuracy and linearity.

NIST-traceable

All optek filters ship with NIST-traceable certification (National Institute of Standards and Technology). optek laboratory is equipped with a high quality, NIST-traceable spectrophotometer assuring quality and quick turn around time for recertification of filters.

Concept

Advantages of optek calibration concept include:

- only 1 filter (set) for multiple sensors ensures identical calibration
- only the filter needs to be sent back for recertification, while the sensor remains operating.

- **Calibration Filters UV-L**

Nominal absorption:
0.45, 0.9, 1.8 and 2.4 CU

- **Calibration Filter UV-B**

Nominal absorption:
> 3 CU

- **Calibration Filters UV-S**

Nominal absorption:
Application specific

- **Calibration Filters VIS-L**

Nominal absorption:
0.45, 0.9 and 1.8 CU

- **Calibration Filters NIR-L**

Nominal absorption:
0.45, 0.9 and 1.8 CU

- **Calibration Case**

Holds up to 7 calibration filters

- **Calibration Cuvette**

The unique calibration cuvette enables product calibration without need to interfere with the process line. It allows users to create a correlation of absorption signals to the concentration of product or an equivalent substance, creating an easy link from lab to process.





Germany

optek-Danulat GmbH
Emscherbruchallee 2
45356 Essen / Germany
Phone: +49 201 63409 0
Fax: +49 201 63409 999
E-Mail: info@optek.de



USA

optek-Danulat Inc.
N118 W18748 Bunsen Drive
Germantown WI 53022 / USA
Phone: +1 262 437 3600
Toll free call: +1 800 371 4288
Fax: +1 262 437 3699
E-Mail: info@optek.com



Singapore

optek-Danulat Pte. Ltd.
25 Int'l Business Park
#02-09 German Centre
Singapore 609916
Phone: +65 6562 8292
Fax: +65 6562 8293
E-Mail: info@optek.com.sg



China

optek-Danulat Shanghai Co., Ltd
Room 718 Building 1
No.88 Keyuan Road
Pudong Zhangjiang
Shanghai, China 201203
Phone: +86 21 2898 6326
Fax: +86 21 2898 6325
E-Mail: info@optek-danulat.com

中国

优培德在线测量设备（上海）
有限公司
上海张江科苑路88
号德国中心718
室 邮编:201203
电话: +86-21-28986326
传真: +86-21-28986325
E-Mail: info@optek-danulat.com



Russian Federation

optek-Danulat GmbH
St.-Petersburg Rep. Office
Kolomjzhskij Pr. 33-A
Office 911
197341 St.-Petersburg
Phone: +7 812 380 72 47
Fax: +7 812 380 72 05
E-Mail: info@optek-danulat.ru

Российская Федерация

Представительство ООО
«оптек-Данулат ГмбХ»
Коломяжский пр-кт, д. 33-А,
офис 911
197341, г. Санкт-Петербург,
Российская Федерация
Тел.: +7 812 380 72 47
Факс: +7 812 380 72 05
E-mail: info@optek-danulat.ru